



Siemeca™

Electronic Heat Meter

WFM407...
WFQ407...
WFP407...
WFO407...

Electronic, battery-supplied meters for determining the heat consumption in autonomous heating and service water systems. Saving and displaying of cumulative values on a selectable due date. Available as compact single-jet meter with nominal flow of 0.6 m³/h, 1.5 m³/h and 2.5 m³/h. The electronic Siemeca™ heat meter can be read out and parameterized via an IrDa interface.

Application

The heat meter is used for measuring heat energy. The major areas of application are heating systems with central heating facilities in which the heating energy is supplied to several consumers as required.

This is useful in:

- Apartment buildings
- Offices and administration buildings

Typical users are:

- Private building owners
- Residential building cooperatives
- Facility management providers
- Real estate management

Functions

- Determination of heat consumption based on the measurement of flow and difference in temperature
- Cumulation of consumption values
- Saving of cumulative consumption values on the due date
- Display of consumption values and optional of significant operating data
- Self-monitoring with error indication
- Parameterisation and read out via optical interface (IrDA-compatible)

Type overview

Type list – heat meters

Place of installation: Return

Nominal Flow q_p	Installation Length	Cable Length	Immersed	Return Sensor	Place of Installation	Type Ref.*
0.6 m ³ /h	110 mm	1.5 m	Direct	Integrated	Return	WFM407.B113
1.5 m ³ /h	110 mm	1.5 m	Direct	Integrated	Return	WFM407.D113
2.5 m ³ /h	130 mm	1.5 m	Direct	Integrated	Return	WFM407.E133
1.5 m ³ /h	80 mm	1.5 m	Direct	Not integrated	Return	WFQ407.D083
0.6 m ³ /h	110 mm	1.5 m	Indirect	Integrated	Return	WFM407.B119
1.5 m ³ /h	110 mm	1.5 m	Indirect	Integrated	Return	WFM407.D119
2.5 m ³ /h	130 mm	1.5 m	Indirect	Integrated	Return	WFM407.E139

Place of installation: Inlet

Nominal Flow q_p	Installation Length	Cable Length	Immersed	Flow Sensor	Place of Installation	Type Ref.*
0.6 m ³ /h	110 mm	1.5 m	Direct	Integrated	Flow	WFP407.B113
1.5 m ³ /h	110 mm	1.5 m	Direct	Integrated	Flow	WFP407.D113
2.5 m ³ /h	130 mm	1.5 m	Direct	Integrated	Flow	WFP407.E133
1.5 m ³ /h	80 mm	1.5 m	Direct	Not Integrated	Flow	WFO407.D083
0.6 m ³ /h	110 mm	1.5 m	Indirect	Integrated	Flow	WFP407.B119
1.5 m ³ /h	110 mm	1.5 m	Indirect	Integrated	Flow	WFP407.D119
2.5 m ³ /h	130 mm	1.5 m	Indirect	Integrated	Flow	WFP407.E139

* Reference code

Scope of delivery – heat meter

Article	Temperature sensor, length and type of immersion					Packing
	80 mm	110 mm, direct	110 mm, indirect	130 mm, direct	130 mm, indirect	
Compact heat meter	•	•	•	•	•	Box
Protective cap	2x	2x	2x	2x	2x	Box
Installation manual	•	•	•	•	•	Box
Start-up and operating instructions	•	•	•	•	•	Box
Flat seal	2x	2x	2x	2x	2x	Bag 1
Seal wire	3x	2x	2x	2x	2x	Bag 1
Self lock seal	3x	2x	2x	2x	2x	Bag 1
Plastic screw for fixing temp. sensors	2x	1x	1x	1x	1x	Bag 2

Sealing ring	4x	2x	2x	2x	2x	Bag 2
Tool for assembly temperature sensors	•	•	•	•	•	Bag 2

Type list – Installation kits

<i>Scope of delivery, description</i>	<i>Type Ref.</i>
For 80 mm installation length, both sensors directly immersed, flow sensor in ball valve	WFZ.E80
For 80 mm installation length, return sensor directly immersed, flow sensor in ball valve	WFZ.E80G3
For 110 mm installation length, return sensor directly immersed, flow sensor in ball valve	WFZ.E110-I
For 110 mm installation length, return sensor indirectly immersed, flow sensor in immersion sleeve	WFZ.E110-IT
For 110 mm installation length, return sensor directly immersed, flow sensor in ball valve	WFZ.E110G3-I
For 110 mm installation length, return sensor indirectly immersed, flow sensor in immersion sleeve	WFZ.E110G3-IT
For 130 mm installation length, return sensor directly immersed, flow sensor in ball valve	WFZ.E130-I
For 130 mm installation length, return sensor indirectly immersed, flow sensor in immersion sleeve	WFZ.E130-IT
For 130 mm installation length, return sensor directly immersed, flow sensor in ball valve	WFZ.E130G1-I
For 130 mm installation length, return sensor indirectly immersed, flow sensor in immersion sleeve	WFZ.E130G1-IT

Scope of delivery – installation sets

<i>Accessories</i>	WFZ-									
	E80	E80G3	E110-I	E110-IT	E110G3-I	E110G3-IT	E130-I	E130-IT	E130G1-I	E130G1-IT
Spacer	•	•	•	•	•	•	•	•	•	•
Ball valve IT* 1/2" for installation in return, union nut** 3/4", with sensor seat, flat seal 3/4"	•	•								
Ball valve IT 1/2" for installation in return, union nut* 3/4", flat seal 3/4"	•	•	2x	2x	2x	2x				
Ball valve IT 3/4" for installation in return, screw connection 3/4" with 1" union nut, flat seal 1"							2x	2x	2x	2x
Ball valve IT 1/2" for installation in flow, with sensor seat	•		•							
Ball valve IT 3/4" for installation in flow, with sensor seat		•			•		•			
Ball valve IT1" for installation in flow, with sensor seat									•	
Tee IT 1/2" for installation in flow				•						
Tee IT 3/4" for installation in flow						•		•		
Tee IT1" for installation in flow										•
Immersion sleeve M10x1				•		•		•		•

* IT = Internal thread

** Union nut integrated in ball valve (cannot be separated)

Type list – Accessories

<i>Accessories</i>	<i>Description, scope of delivery</i>	<i>Type Ref.</i>
Spacer	For installation length of 80 mm, external thread 3/4"	WFZ.R80
Spacer	For installation length of 110 mm, external thread 3/4"	WFZ.R110
Spacer	For installation length of 130 mm, external thread 1"	WFZ.R130
Ball valve	Internal thread 1/2", with sensor seat	WFZ.K15
Ball valve	Internal thread 3/4", with sensor seat	WFZ.K18
Ball valve	Internal thread 1", with sensor seat	WFZ.K22
Tee	Internal thread 1/2", with immersion sleeve M10x1	WFZ.T16
Tee	Internal thread 3/4", with immersion sleeve M10x1	WFZ.T19
Tee	Internal thread 1", with immersion sleeve M10x1	WFZ.T22
Threaded joints	Profipress G-Adapter with SC-Contur, gunmetal, female thread, 15x 1/2"	WFZ.P2
Threaded joints	Profipress G-Adapter with SC-Contur, gunmetal, female thread, 18x 3/4"	WFZ.P2-1
Parameterisation and diagnosis tool	PC-software tool (additional tool required: with USB-Tool set WHZ3.USB or IrDA interface F12150-2018 on Com (RS232) port)	ACT20

Order

When ordering, specify the type reference according to the type overview. The standard electronic Siemeca™ heat meter has an IrDA interface.

If a due date other than the 31 December is desired, the desired month should also be entered in addition to the type reference (the last day of a month is always the due date).

Order model for a heat meter with **110** mm installation length and 30 April as due date:
WFM407.B113, Due date: April

Technology

Measuring principle

The meter operates according to the single-jet measuring principle. The water flows against an impeller; its speed is scanned electronically and without a magnetic field. The temperatures in the flow and return are measured with immersion sensors Pt1000 (platinum measuring elements).

Determination of heat consumption

The heat meter is equipped either for installing in the return or in the flow. Please select the corresponding meter from the type list for the place of installation.

The flow is continuously measured in the calculator and at least once every minute the flow and return temperature. A microprocessor in the calculator determines the difference in temperature and calculates the consumed quantity of heat based on the average flow and the heat coefficient.

Saving of consumption values

The heat consumption values are totalled continuously. The current state is saved on the next due date at 24.00 h.

The due date can be factory-programmed; the standard due date is entered as 31 December (compare «Order»)

When the annual consumption is saved, the heat meter simultaneously calculates a control number. After special parameterisation with ACT20 service software the checksum is readable. Self-readers must inform the utility company/property management of this control number and the due date value that has been read out so that they can check that the display has been read correctly.

The due date value remains saved for one year.

Display

The heat meter has a scrolling display with the following values and variables:

- Cumulative heat consumption since starting up the heat meter
- Segment test
- Due date
- Cumulative water consumption up to last due date

With the aid of the Siemeca™ parameterization tools the following display options can be activated:

- Due date (only if due date and cut off date are different)
- Control number
- Current flow
- temperature Difference
- Error display (see also following section)

Error messages

The heat meter is self-monitoring and can display errors that have been detected. The cumulative values remain saved until the error occurs for the first time.

Version

The heat meter comprises the flow meter, the calculator and both temperature sensors. The flow meter is screw connected to the pipe; it is made of brass and contains the metering chamber with the single-jet impeller sensor. The inlet connection has a filter to trap large dirt particles.

The heat meter is a compact version.

Calculator

The calculator contains the electronics and the 8-digit display (LCD). The operating voltage of DC 3 V is supplied by a lithium battery. The IrDA interface for automatically reading out the readings is located beneath the display. The calculator on the flow meter can be rotated 360°.

Temperature sensor

The temperature sensors can be installed either indirectly or directly immersed. The sensor comprises the protection sleeve at the end of which is the measuring element Pt 1000 and the PVC cable that connects it (fixed) to the calculator. The temperature sensors are mounted in the ball valves with the temperature sensor seat either (directly immersed) or in Tee with immersion sleeves (indirectly immersed). Mounted (fixed), approved, pairs of and certified temperature sensors are used.

Determination of pressure loss

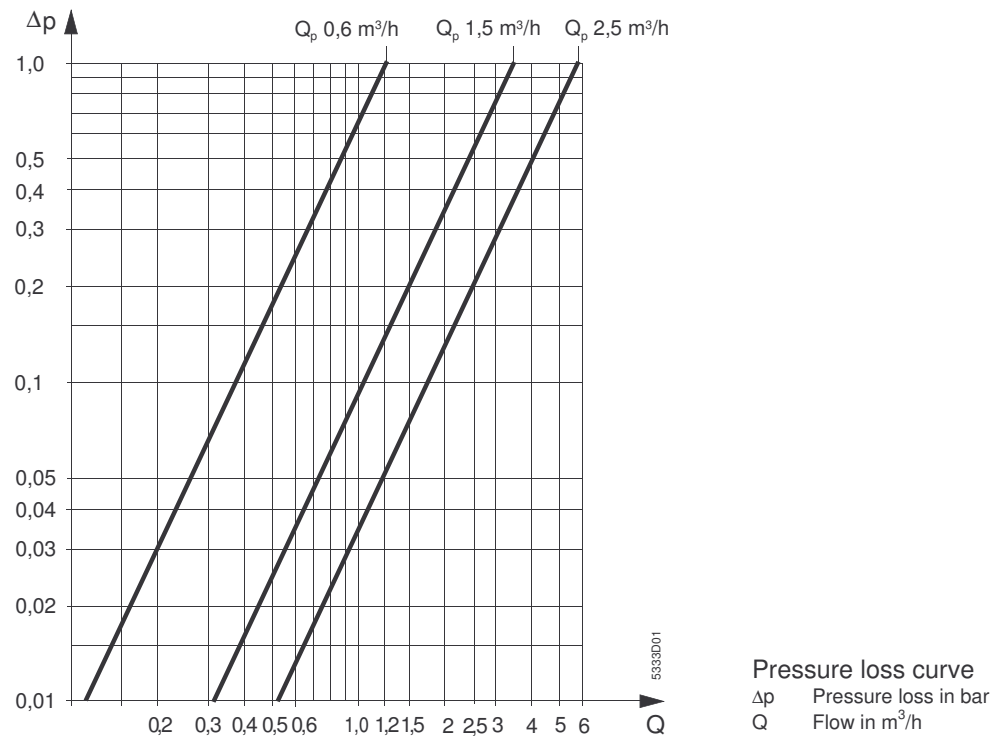

Mounting instructions

- Observe the local regulations for the use of heat meters (mounting, sealing, operation, etc.).
- Mount the heat meter according to the type either in the flow or return between two shut-off valves. It must be easily accessible for reading and service work.
- A stilling channel is required at the inlet in front of the device:
 - 150 mm for installation lengths of 80 mm and 110 mm
 - 200 mm for an installation length of 130 mm
- If the device is only to be used when starting up, the spacer can be mounted first.
- Before installing the meter, rinse the pipe well; mount the spacer for this purpose.
- When installing, observe the flow sign – an arrow on the flow meter.
- If tees of a different brand are used, ensure that they comply with the standard EN1434!
- Position the calculator so that the display is easy to read.
- After mounting, test the system for pressure.
- Protect the calculator, both temperature sensors and the screw pipe connections with seals against unauthorized access.
- Insulate the lead at the installation site of the temperature sensors.

Operating hint

- Observe the local regulations for recalibration purposes.

Technical data

Metrological accuracy class	3 as per EN 1434 ratio $q_s / q_p = 2 : 1$ ratio $q_p / q_i = 25 : 1$ vertical ratio $q_p / q_i = 50 : 1$ horizontal			
Environmental class	A as per EN 1434			
Energy unit				
Standard	kWh			
On request	GJ			
Flow values	0.6 m ³ /h	1.5 m ³ /h	2.5 m ³ /h	
Minimum flow q_i				
Horizontal	12 l/h	30 l/h	50 l/h	
Vertical	24 l/h	60 l/h	100 l/h	
Nominal flow q_p	600 l/h	1500 l/h	2500 l/h	
Maximum flow q_s	1200 l/h	3000 l/h	5000 l/h	
Starting value – horizontal	4 l/h	10 l/h	16 l/h	
Upper limit of thermal power P_s	0.6 m ³ /h	1.5 m ³ /h	2.5 m ³ /h	
	125 kW	313 kW	523 kW	
Quality of heating water	VDI guide line 2035 (VDI – union of german engineers)			
Max. permissible operating pressure	10 bar			
Range of use – flow meter	15... 90 °C			
Temperature measurement				
temperature range of sensor	15...105 °C			
temperature difference	3...90 K			
Behaviour of flow				
Flow $\leq 2,1 * q_p$	Linear			
Flow $> 2,1 * q_p$	Constant			
Permissible ambient temperature				
Transport and storage	-20 °C .. +70 °C			
Operation	+5 °C .. +55 °C			
Battery life time	10 years + ½ years			
Connection sizes and mass	0.6 m ³ /h	1.5 m ³ /h	1.5 m ³ /h	2.5 m ³ /h
threaded end connections	G ³ / ₄ B	G ³ / ₄ B	G ³ / ₄ B	G1B
Installation length	110 mm	80 mm	110 mm	130 mm
Mass	kg	kg	0.60 kg	kg
Temperature sensor				
temperature sensing element	Pt 1000 as per EN 60751			
Temperature probe type	Short DS			
response time $\tau_{0,5}$	$\leq 3,5$ s			
diameter of protective sheath	5 mm			
Connecting lead	1.5 m			
Standards, CE	EN 61000-4-3:2002+A1:2002			
	DIN EN 61000-4-Parts 2,4,8			
	DIN EN 55022			
	DIN EN 1434, (1997, 2002)			

Dimensional drawings

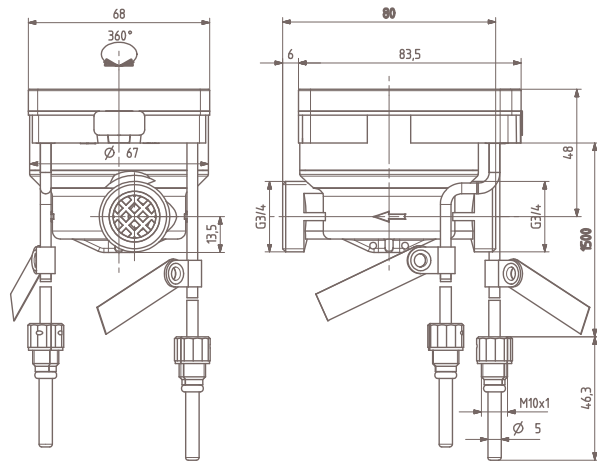

Installation length
80 mm

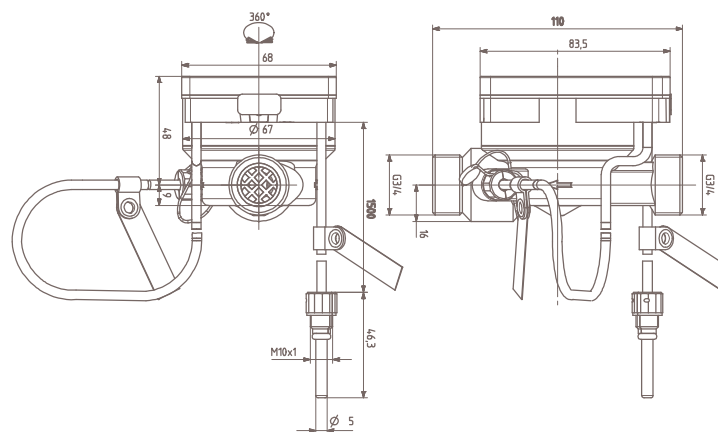

Installation length
110 mm

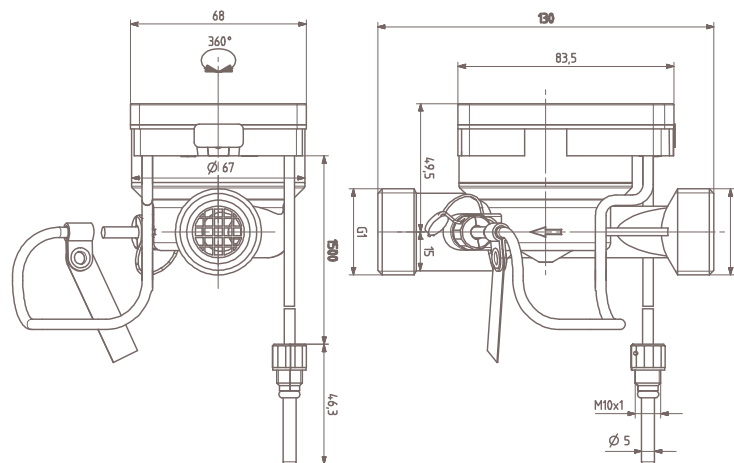

Installation length
130 mm

This Data Sheet only contains general descriptions and technical features which, in the case of specific applications, may not necessarily apply, or which may change due to further development of the product. Technical details and features are binding only if explicitly agreed upon at the time of contract closure.

©2004 Siemens Building Technologies AG
Subject to alterations